

The Siemens logo, consisting of the word "SIEMENS" in a bold, teal, sans-serif font, is positioned in the top left corner of the slide. It is set against a white rectangular background that partially overlaps the blue hexagonal pattern of the slide's header.

**SIEMENS**

Siemens/ Wolfspeed | April 20<sup>th</sup> 2016

**Novel Temperature Sensors and Wireless Telemetry for Active  
Condition Monitoring of Advanced Gas Turbines**

**DOE Award: DE-FE-0026348**

**Anand Kulkarni, Siemens Corporation**

**Acknowledgements: DOE NETL  
Sydni Credle – Project Manager**

# Anatomy of a Smart Component

Data acquisition enables real-time input to life models



Real-time monitoring of component condition enables condition-based maintenance

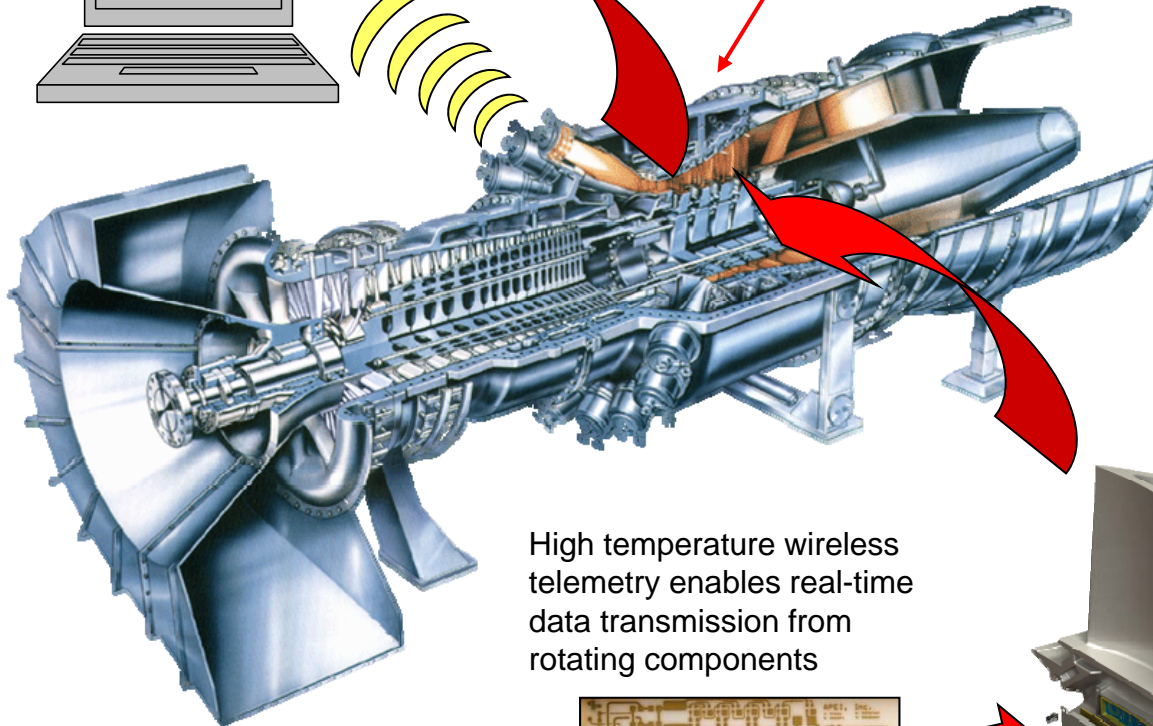

Thermal spray processes enable cost-effective, integrated sensors



High temperature wireless telemetry enables real-time data transmission from rotating components

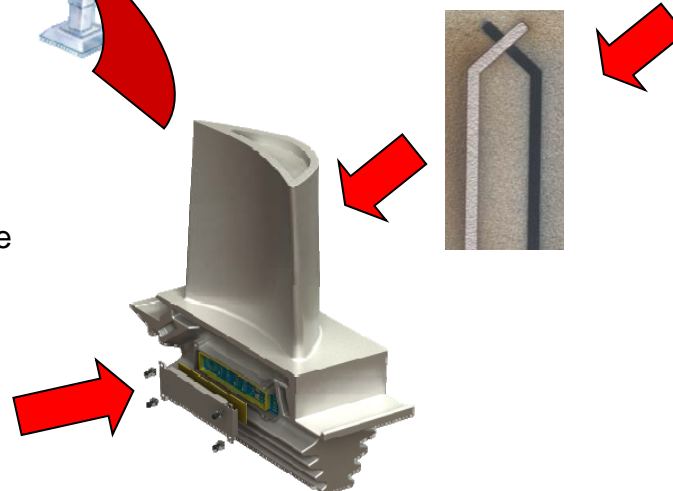
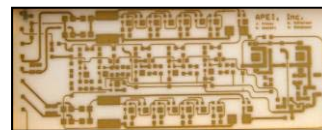

# Deployment of Advanced Sensing Systems Enables Operational Based Assessment

- Harsh environment instrumentation provides critical information regarding component condition
- Such information provides data for:
  - Test engine evaluation
  - Design model validation
  - Engine performance
  - Engine diagnostics
  - Conditioned based assessment
- Improvements over existing instrumentation is required to obtain long life data from fleet engines.
- Enables a paradigm shift in engine operation

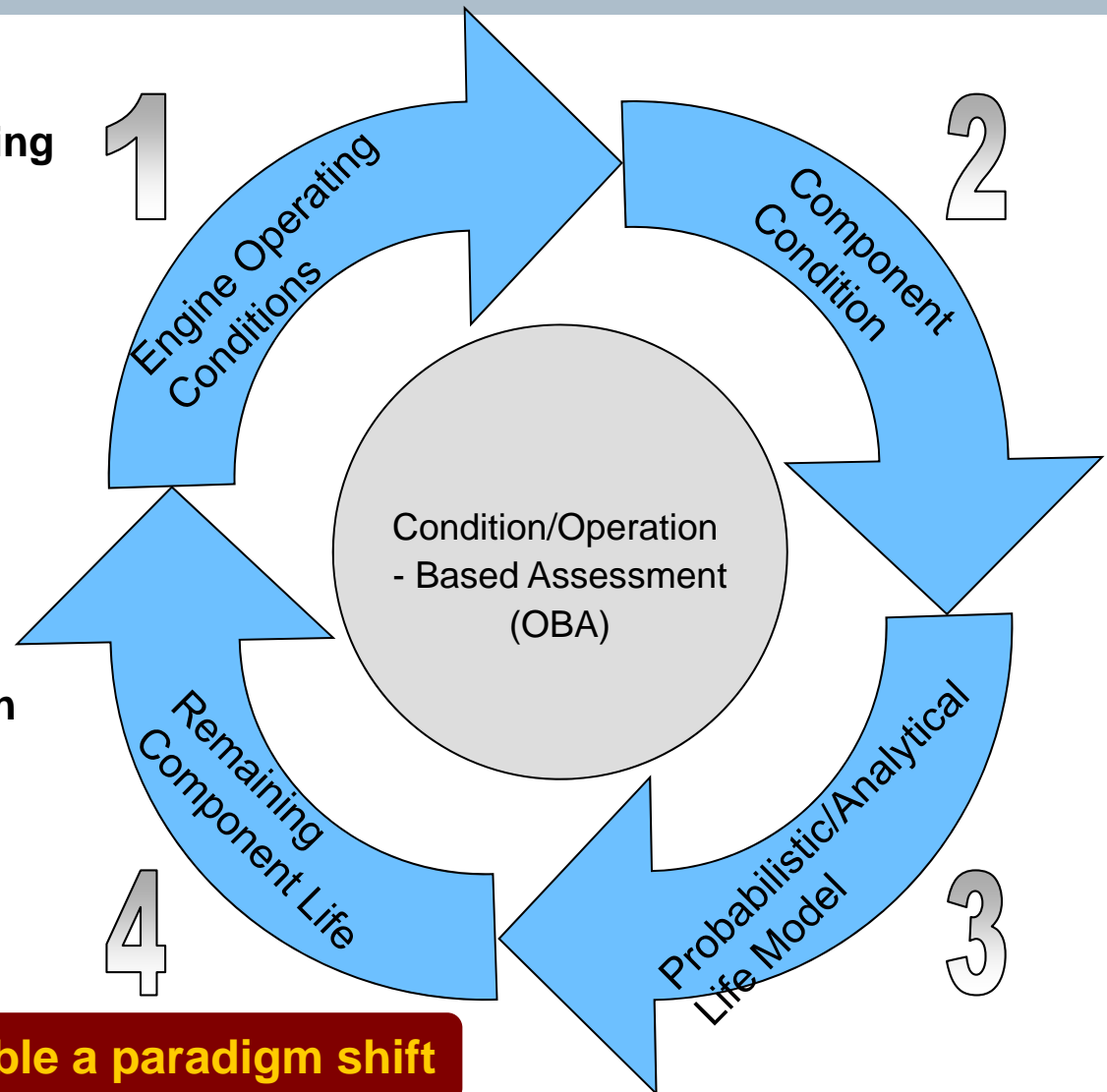

**Advanced sensor systems enable a paradigm shift**

# Current Blade Measurement Methodology

## Current method of blade instrumentation

- Wires from blade rings down entire length of rotor
- Time consuming – 3-6 months per validation
- Expensive - \$2-3 Million per validation
- Damages rotor; costly replacement

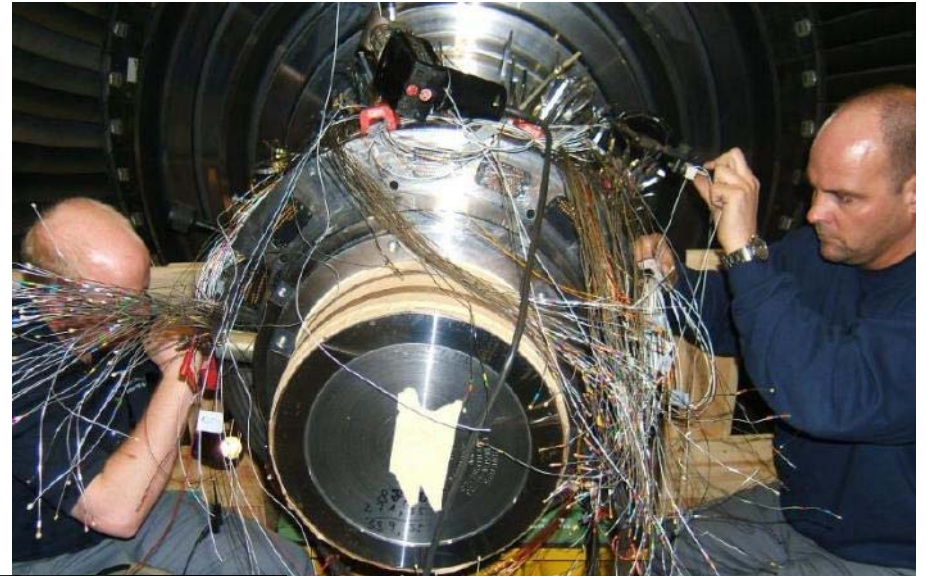

# Paradigm Shift for Engine Monitoring

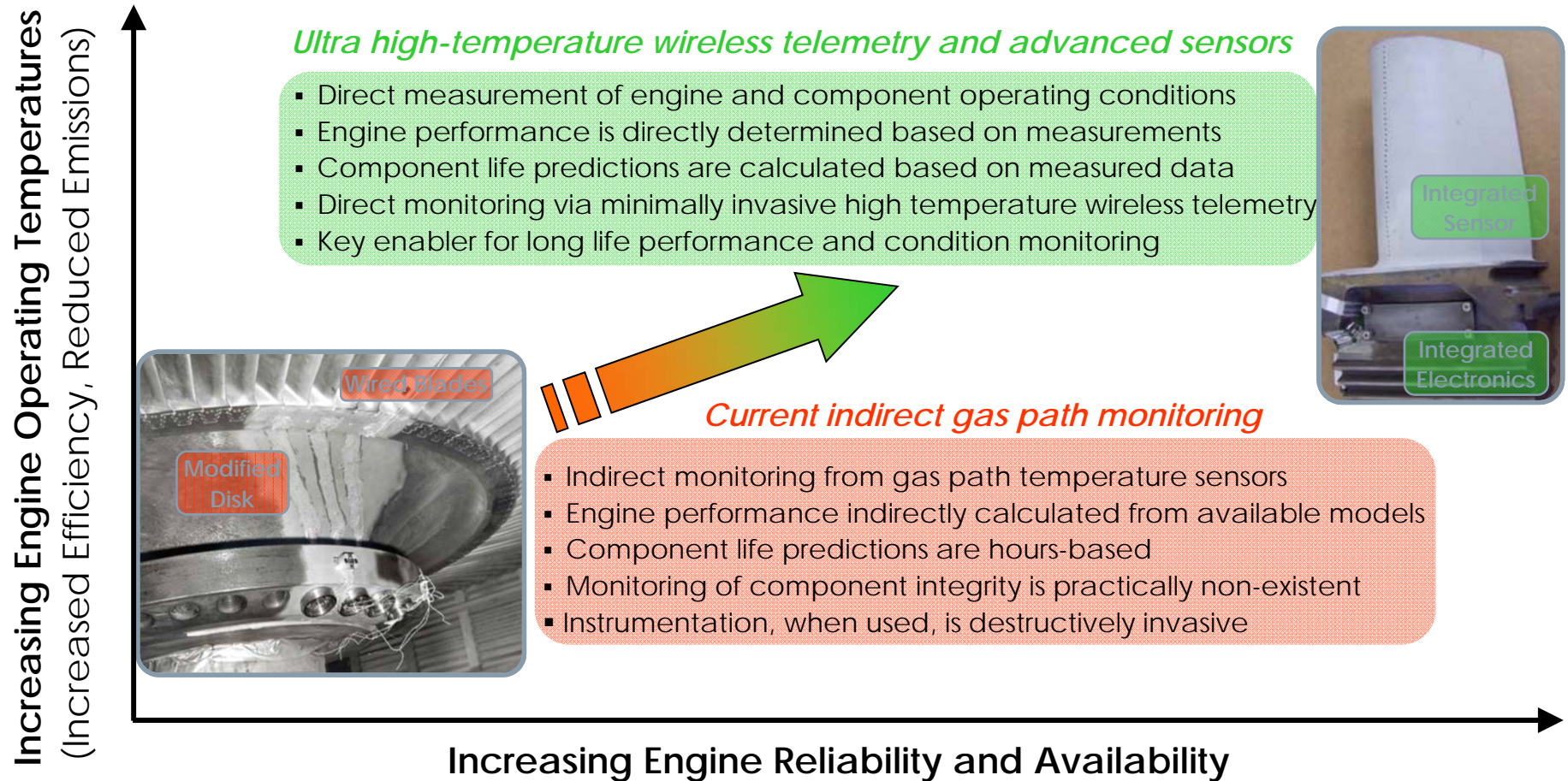

## Path Forward

### Leverage Success from Previous Projects

- 350 C operation → 550 C operation
- Single channel boards → Multi-channel boards
- 500mW, high ripple power transfer → 2000mW, no ripple power transfer

### Advanced Testing in Demanding Environments

- Heated, Rotating Rig (Aerodyn)
- Engine Installation (SGT-800 @ Siemens)

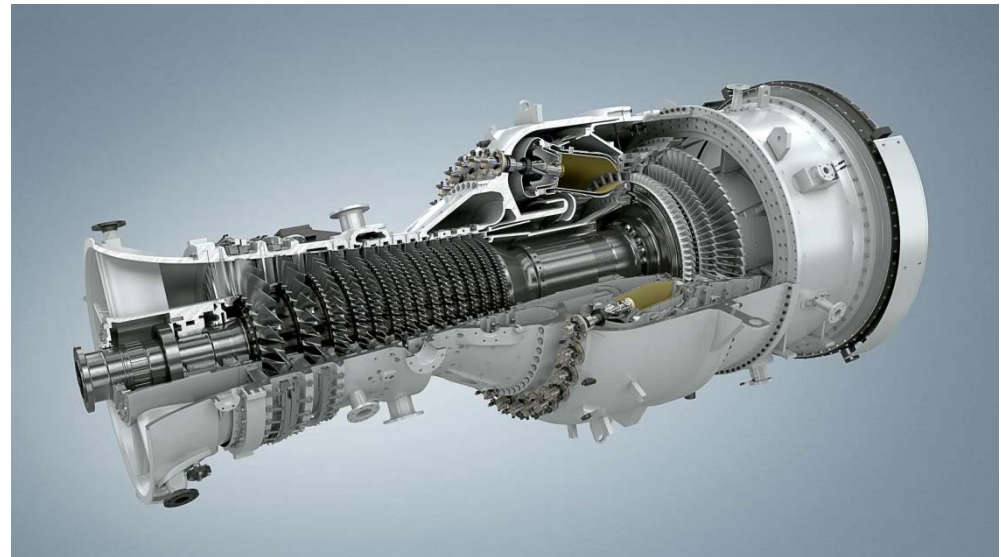
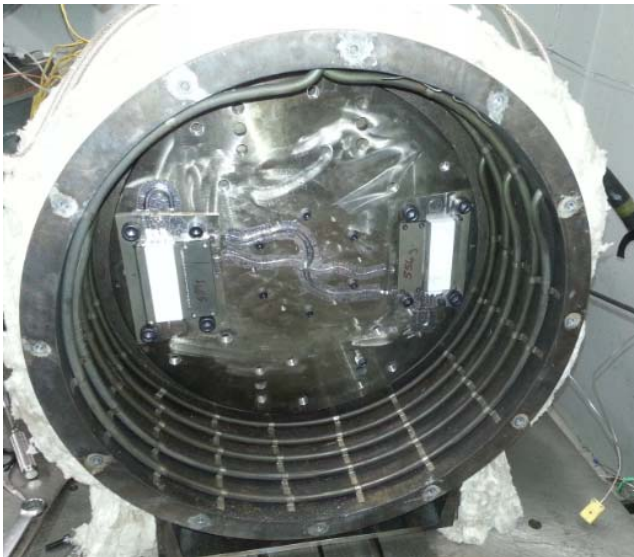

## Benefits If Successful

### Online Condition Based Monitoring

- Multi-Thousand Hour Lifetime
- Reduce component-life-based shutdowns
  - \$1-2 Million savings
  - Machine on time increased 1-2% annually
- Online Engine Operation for Efficiency Gains

### Feedback for Design Optimization

- Online Blade Condition more widespread
- No wires → higher accuracy
- Strain amplitude error  $\pm 30\%$  →  $\pm 5\%$

### Summary

- Higher engine on-time
- More design feedback
- Online feedback → Operational optimization → higher engine efficiency
- Push forward extreme high temperature electronics

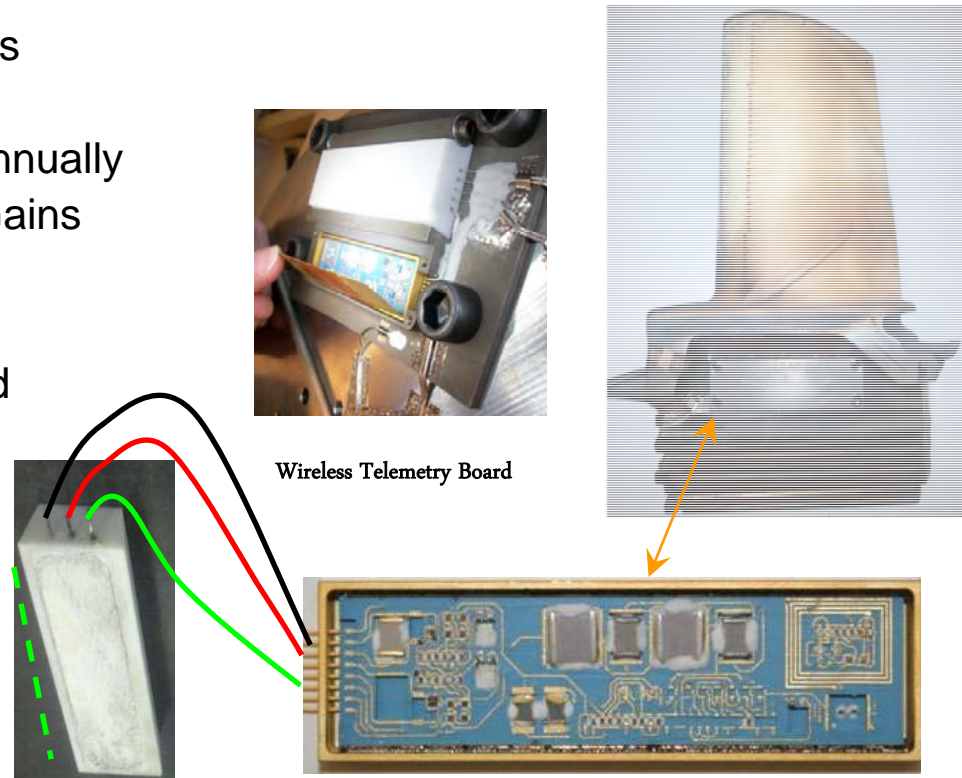

# Novel Sensors- Wireless Telemetry System Team

## HT Capable Thermally Sprayed Sensors

- Siemens
  - Specifications
  - Ultra high temperature testing
  - Sensor optimization
- Curtiss Wright
  - Sensor Fabrication
- Hitec Products
  - Attachments

## HT Wireless Telemetry Transmitter Circuit Board

- Siemens
  - Specification
  - Attachment Design
- Wolfspeed
  - Telemetry Circuit Board
  - Advanced SiC IC Devices

## High Temperature Induced Power System

- Siemens
  - Attachment design
- Wolfspeed
  - Wireless Telemetry System
- Aerodyn
  - High Temperature Spin Tests

## Engine Component Modification and Analysis

- Siemens
  - OBA, Design and Analysis
- Machining Vendors
  - Component Fab

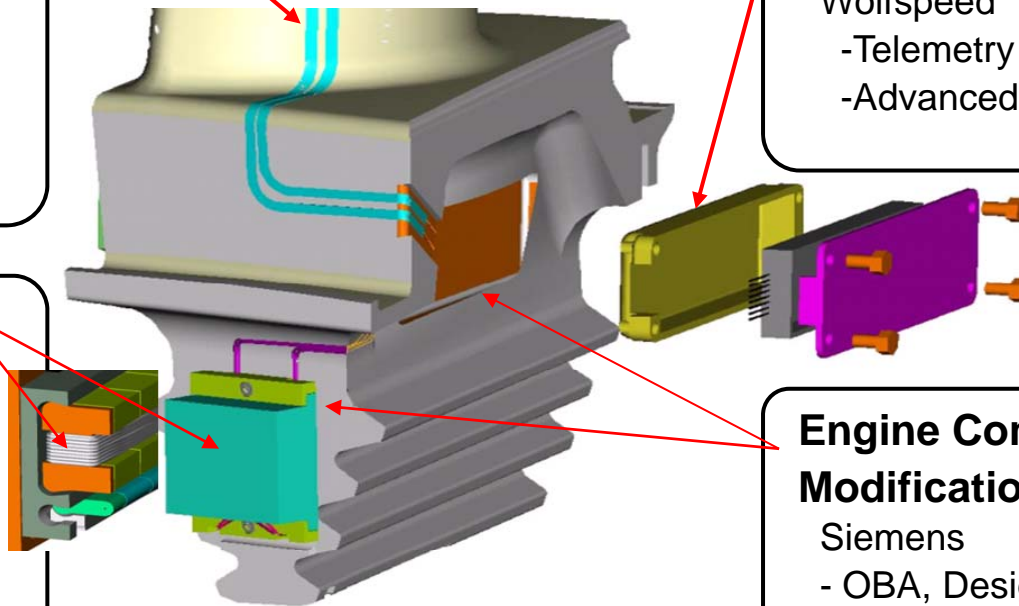

**The technical team is strong and has been working together for 10 years**



# Thick Film Sensor Deposition via Thermal Spray Process

Thermal spray enables integral sensors to be deposited on coated and uncoated components with complex shape.

Sensors may be incorporated with minimal component and performance modifications.

The process can be done at high speeds, efficiently, and at low cost.

Sensor deposition may be performed using masking and conventional thermal spray hardware

Thermocouples with various compositions are being developed and tested.

The EMF output of the various thermally sprayed TC compositions was measured during heating to more than 1000° C.

The greater the EMF output, the better the signal-to-noise (S/N) ratio of the sensor.

The Type 1 TCs are the least sensitive, but are nearest to production ready. The more advanced compositions will be phased in as their development status matures.

Thermocouple deposited on a performance and calibration test bar.



Thermocouple deposited on a furnace cycle test button.

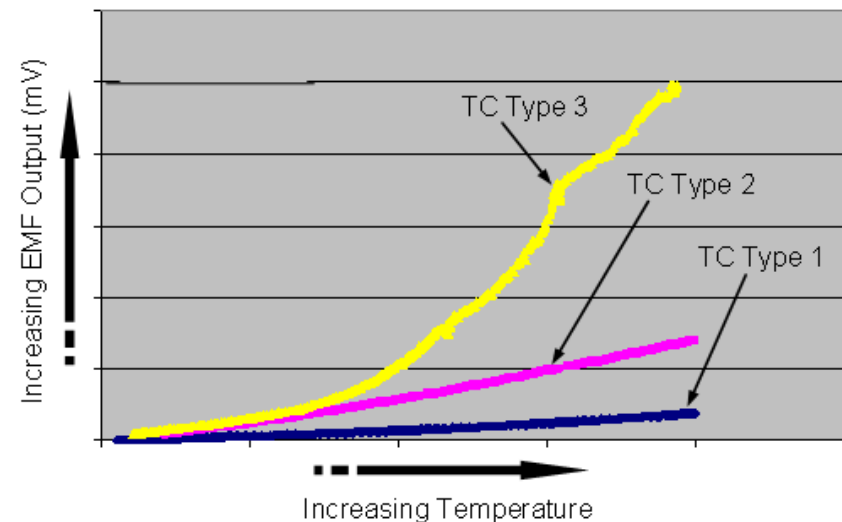
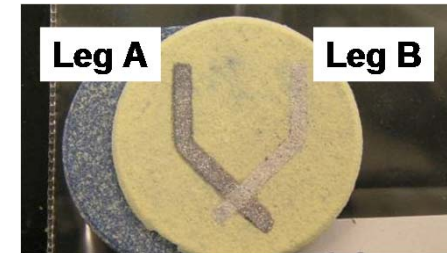

## Impact of sensors on TBC life is minimal

- Thermally sprayed sensors are deposited using the same process as TBCs, and as such, should have a minimal impact on TBC life.
- Thermally sprayed sensors minimize surface perturbations, resulting in more accurate data and longer sensor life.
- Cyclic furnace testing to greater than 1000° C was performed and the data demonstrated that the thermally sprayed sensors do not change the failure mechanism and have minimal impact on TBC life.

Specimen configuration tested.

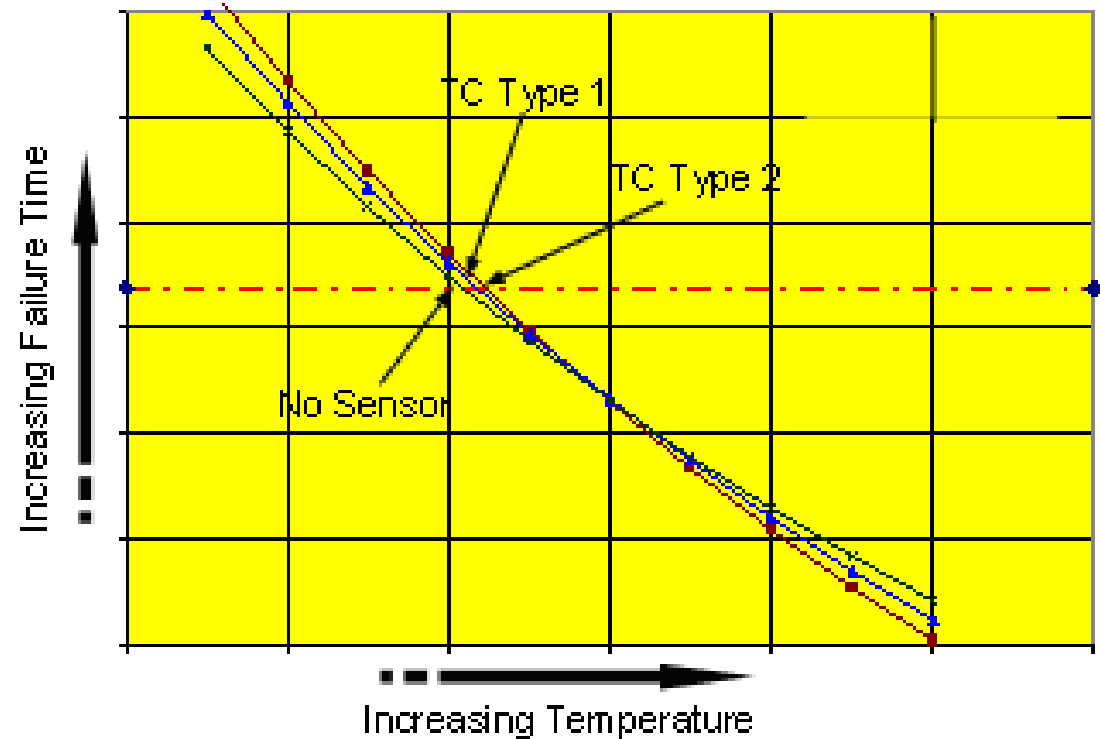
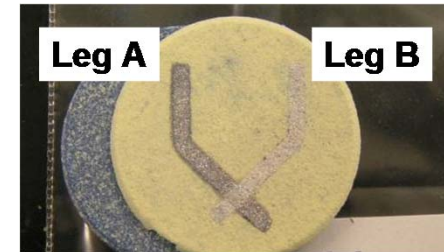

## Structure of a Wireless Telemetry System

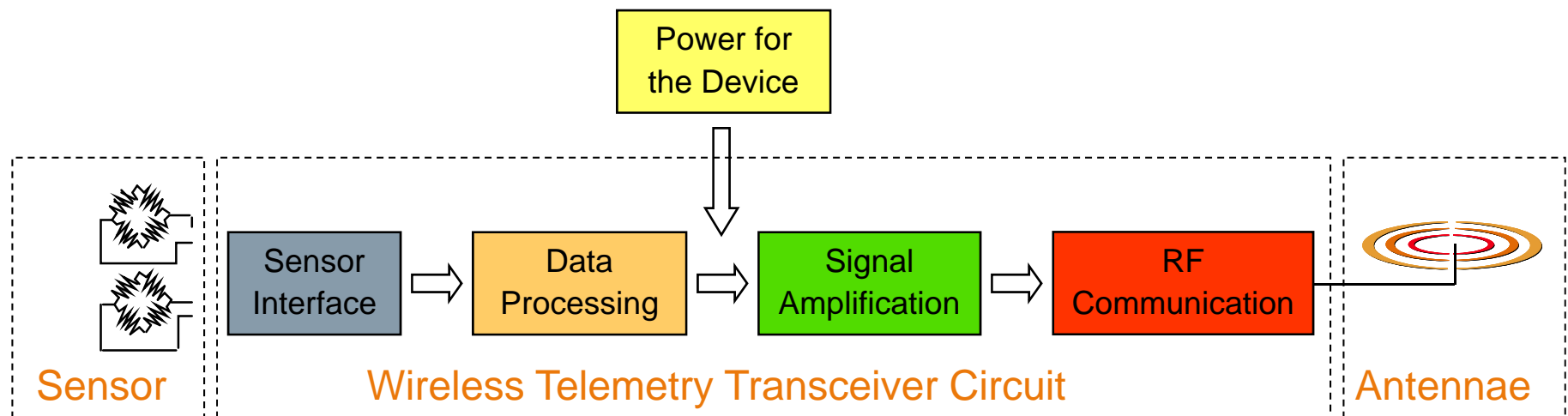

- **Hardwiring rotating parts through rotor is expensive and time consuming.**
- **Wireless telemetry has been used for many years, but not uncooled at high ambient temperatures.**
- **Antennae, circuit board, and electrical run materials, die attach and wire bond processes all must be optimized for functionality and stability at elevated temperatures and high g-loads.**
- **The active devices used on the circuit board must be capable of operation at high temperatures (devices such as SiC, AlN, etc. are required).**
- **A source of power must be provided to the circuit at high temperature.**

# Wireless Telemetry Developments

## Development Background

- APEI led the development of the world's first  $>350^{\circ}\text{C}$  fully wireless telemetry system
- The system was comprised of ~25 discrete SiC transistors, along with innovative high temperature, high g-load packaging techniques

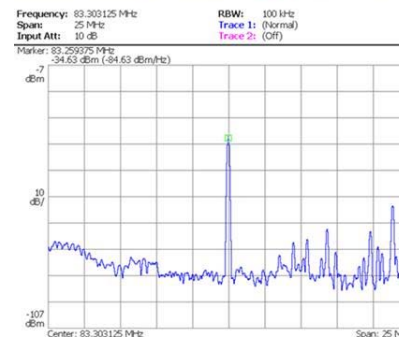
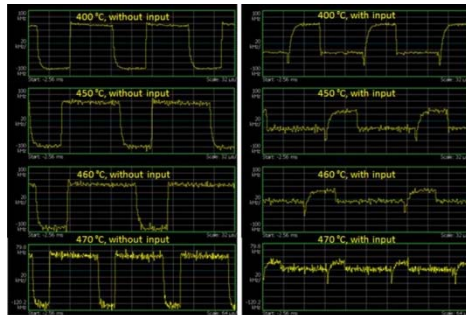

## Planned Innovations

- Wolfspeed will dramatically increase the capabilities of the HT wireless telemetry paradigm
- More comprehensive integration to the turbine at a systems level
- Introduction of state-of-the-art SiC Integrated Circuits (ICs)
- Implementation of completely innovative circuit designs, with novel circuit architectures
- Highly ruggedized packaging approach based on advanced materials and interconnection strategies

## Wireless System Blocks

- The wireless telemetry system is based on wideband frequency modulation
- The system receives wirelessly induced AC power, which must be rectified, filtered, and regulated to a stable DC voltage
- Each sensor (thermocouple) signal must be amplified to a higher level, while rejecting noise
- The sensor(s) amplified outputs are then multiplexed together, along with information on the local temperature of the system
- This multiplexed signal is then frequency modulated onto the wireless carrier signal, which is transmitted to a remote receiver

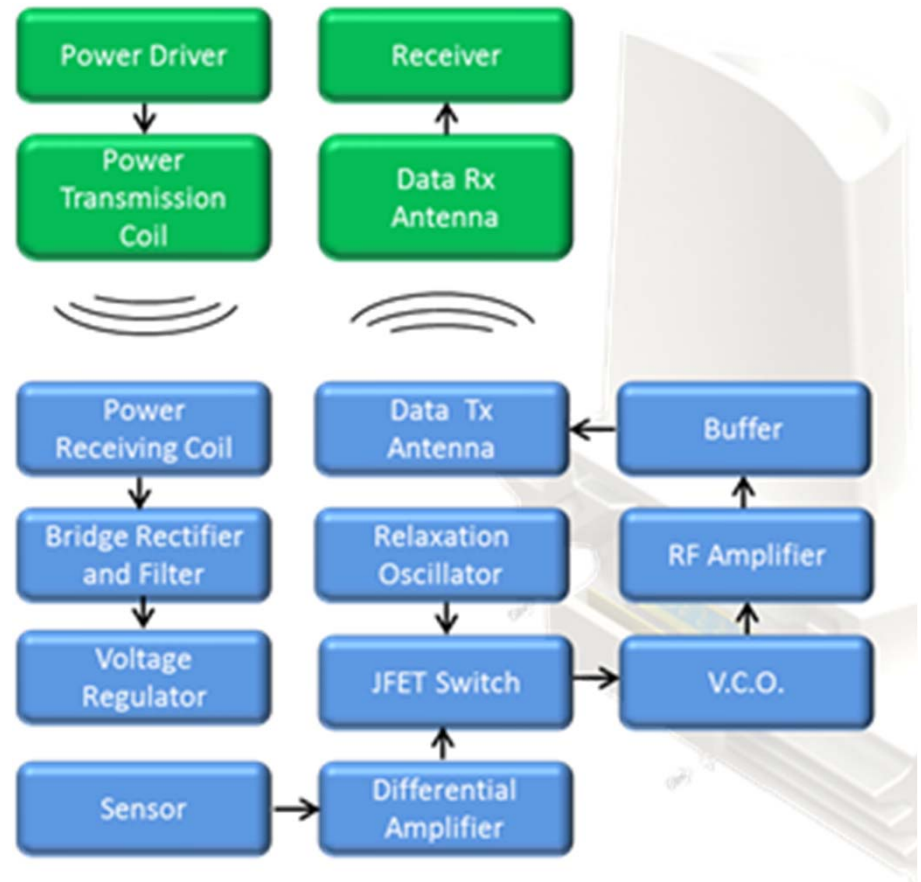

# Design Challenges

## Electronics Boards

- Operating temperature 200+ °C higher than silicon technology can survive
- Thermal expansion and 14,500 g load make electrical connections very difficult
- Vibration and g-load cause cracking of ceramic boards
- Thermal cycling causes metal trace delamination
- Bond wire failures (breaking and g-load flexing)

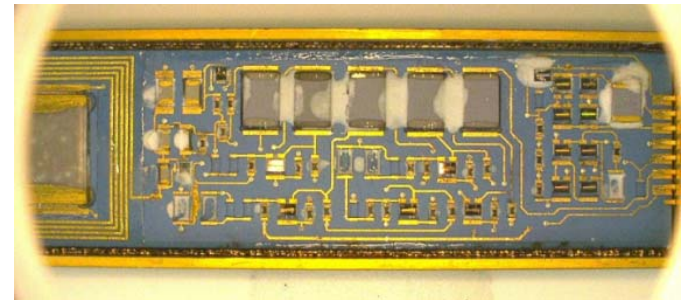

## Rotating Antenna

- Must receive ~1 watt; only 10 cm long; 20mm gap
- Surrounded by grounded metal
- No metal enclosure (magnetic receiver)
- Metal-ceramic interfaces – high vibration and g-load
- Magnetic properties vary greatly over 0-400 °C range



## Stationary Power Inducing Ring

- Magnetic materials infeasible – too much variation in field strength over temperature
- Thermal expansion and vibration make electrical connections very difficult
- Mounted on grounded metal
- Ceramic/metal interface in high vibration environment
- Need 400 °C, high frequency cables

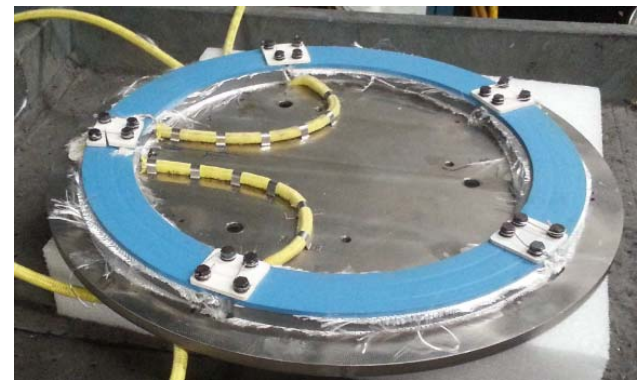

# Progressive Development Approach

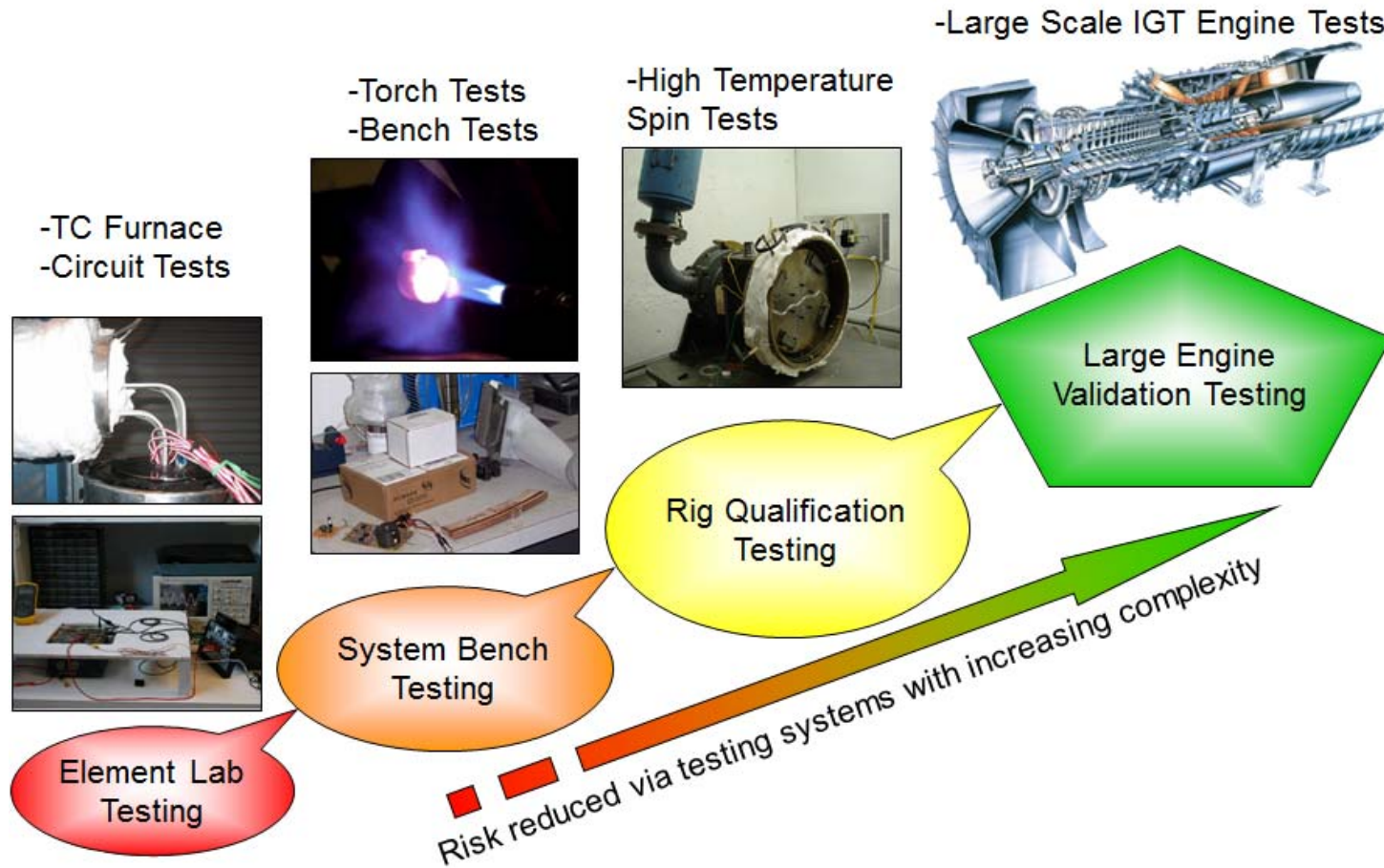

**Rigorous testing and validation based on a thorough understanding of failure modes and improving final system performance**

# Operational Based Assessment

Prognostic health monitoring system comprises (a) instrumented components with relevant sensors, (b) telemetry for data acquisition/transmission to electronics for processing sensor signals, and (c) system architecture for analyzing sensor data, perform statistical prediction analyses for health forecasting.

Onset of Failure modes

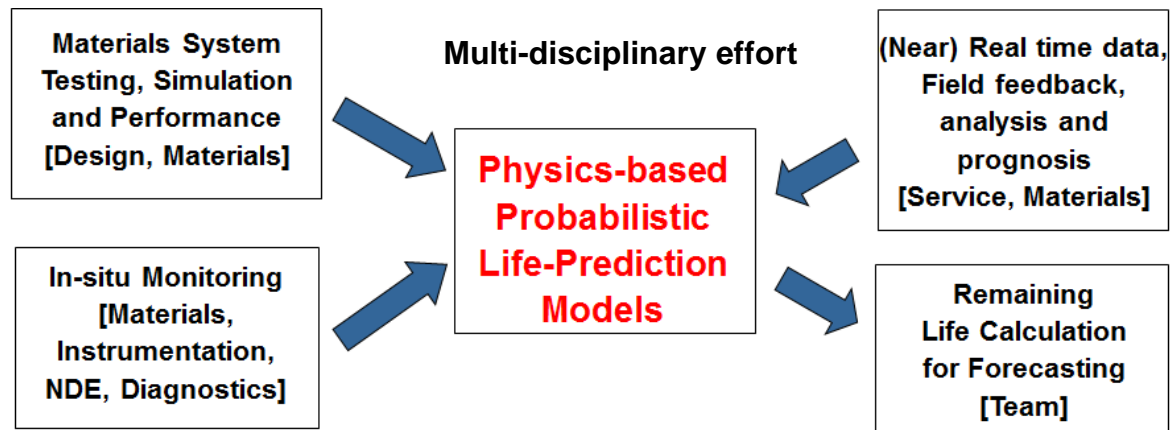
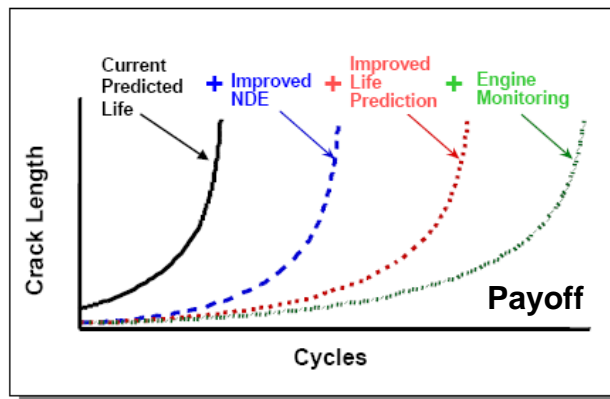
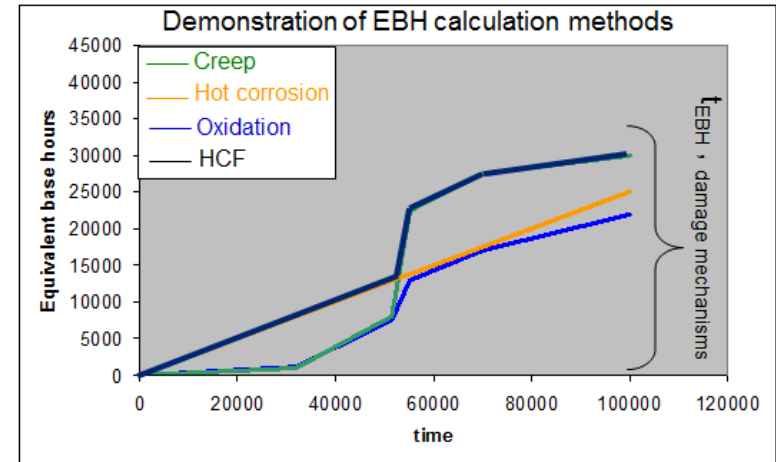

**Utilizing Engine Feedback to Materials design/life forecasting**



# OBA Is An Integration of Numerous Tools and Processes

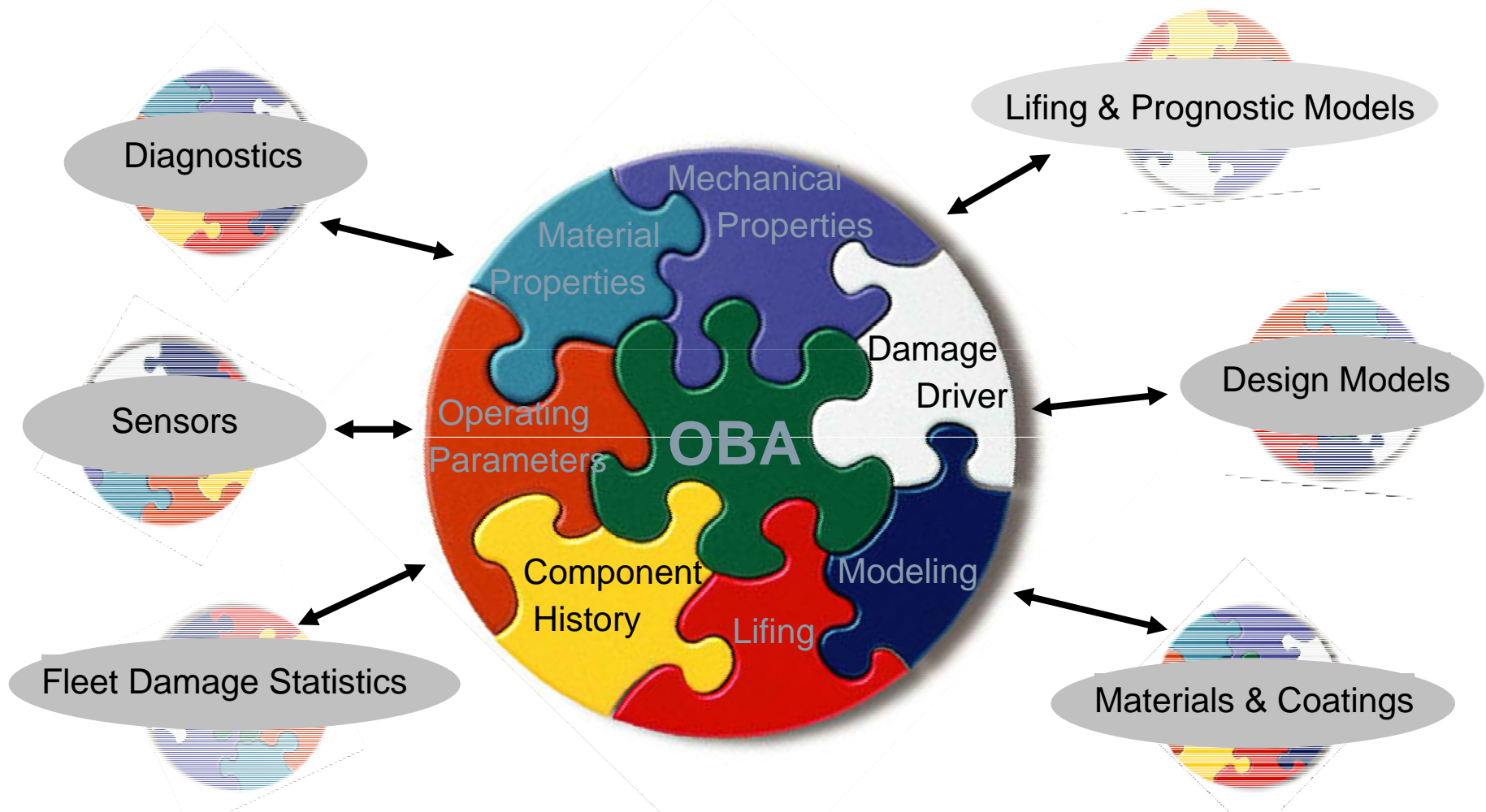

**Materials prognostics integrates complex heterogeneous inputs**

## Summary

- **Real-time information regarding the condition of critical turbine components will enable a transition to condition-based maintenance.**
- **Siemens and its partners are developing Smart Component systems to provide real-time information for stationary and rotating components.**
- **Significant advancements are needed in the area of sensors in order to develop high temperature, reliable sensors for industrial gas turbines**
- **Significant advancements are required in order to enable obtaining information from rotating hot gas path components in a distributed manner, i.e. individually from each component**
- **A progressive validation approach is required for developing advanced sensor systems**
- **Additional effort is required in order to improve the cost, performance, reliability, and lifetime of these novel Smart Component systems; However, the systems show promise in providing real-time information from within the harsh environment of the industrial gas turbine engine.**